

**TM 55-1615-226-40**

**TECHNICAL MANUAL**

**GS MAINTENANCE MANUAL  
INCLUDING REPAIR PARTS AND SPECIAL TOOLS LIST  
SCISSORS AND SLEEVE ASSEMBLY  
PART NUMBERS**

**204-011-401-5**

**204-011-401-9**

**204-011-401-7**

**204-011-401-11**

This manual supersedes TM 55-1615-226-40, 30 January 1969, including all changes.

---

**HEADQUARTERS, DEPARTMENT OF THE ARMY**

**30 AUGUST 1974**

## **WARNING**

### **PRECAUTIONARY DATA**

Personnel performing operations, procedures, and practices which are included or implied in this work requirement shall observe the following warnings. Disregard of these warnings and precautionary information can cause serious injury, death, or destruction of material.

#### **CLEANING SOLVENTS**

Cleaning solvents may be toxic. Use in well ventilated areas. Avoid prolonged inhalation of fumes or direct contact with skin. Do not use solvents near open flame or in areas where very high temperatures prevail.

#### **COMPRESSED AIR**

Do not direct compressed air near or directly against skin. Do not use air under high pressure, or from a source not having a moisture-trap when drying parts. Do not roll bearings with compressed air.

#### **TOXIC POISONS**

Lubricating oil contains additives which are poisonous and are readily absorbed through the skin. Avoid prolonged contact with the skin.

#### **TRANSMISSION TEST STAND OPERATION**

Test stand shall be operated by authorized personnel only.

#### **NOISE**

Operation and maintenance personnel shall wear ear protection devices when working near or around an operating transmission test stand.

#### **WARNING**

An operating procedure, practice, etc., which, if not correctly followed, could result in personnel injury or loss of life.

#### **CAUTION**

An operating procedure, practice, etc., which, if not strictly observed, could result in damage to or destruction of equipment.

#### **NOTE**

An operating procedure, condition etc., which it is essential to highlight.

CHANGE }  
NO. 4 }

HEADQUARTERS  
DEPARTMENT OF THE ARMY  
WASHINGTON, D.C., 30 September 1992

GS Maintenance Manual

SCISSORS AND SLEEVE ASSEMBLY

PART NUMBERS

204-011-401-5	204-011-401-9
204-011-401-7	204-011-401-11

TM 55-1615-226-40, 30 August 1974, is changed as follows:

1. Remove and insert pages as indicated below. New or changed text material is indicated by a vertical bar in the margin. An illustration change is indicated by a miniature pointing hand.

Remove pages

1-1 and 1-2  
- - - -  
2-1 and 2-2  
2-4A/2-4B  
2-5 and 2-6  
2-9 and 2-10  
2-13 through 2-15

Insert pages

1-1 and 1-2  
0-2.1 and 0-2.2  
2-1 and 2-2  
2-4A and 2-4B  
2-5 and 2-6  
2-9 and 2-10  
2-13 through 2-15/2-16

2. Retain this sheet in front of manual for reference purposes.

By Order of the Secretary of the Army:

GORDON R. SULLIVAN  
General, United States Army  
Chief of Staff

Official:

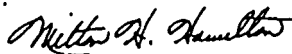

MILTON H. HAMILTON  
Administrative Assistant to the  
Secretary of the Army  
02623

DISTRIBUTION:

To be distributed in accordance with DA Form 12-31-E, block no. 1924, requirements for TM 55-1615-226-40.



CHANGE )

No. 3 )

HEADQUARTERS  
DEPARTMENT OF THE ARMY  
WASHINGTON, DC., 31 December 1975

## GS Maintenance Manual

## SCISSORS AND SLEEVE ASSEMBLY

## PART NUMBERS

204-011-401-5      204-011-401-9

204-011-401-7      204-011-401-11

TM 55-1615-226-40, 30 August 1974, is changed as follows:

1. Remove and insert pages as indicated below.

	Remove pages	Insert pages
Section II	2-3 and 2-4	2-3 thru 2-4A/2-4B

2. New or changed text material is indicated by a vertical bar in the margin. An illustration change is indicated by a miniature pointing hand.

3. Retain this sheet in front of manual for reference purposes.

By Order of the Secretary of the Army:

Official:

**PAUL T. SMITH**

*Major General, United States Army  
The Adjutant General*

**FRED C. WEYAND**

*General, United States Army  
Chief of Staff*

## DISTRIBUTION:

To be distributed in accordance with DA Form 12-31 Direct and General Support Maintenance Requirements for UH-1B, UH-1C/M and UH-1D/H aircraft.



CHANGE }  
 No. 2 }

HEADQUARTERS  
 DEPARTMENT OF THE ARMY  
 WASHINGTON, DC., 10 October 1975

GS Maintenance Manual

SCISSORS AND SLEEVE ASSEMBLY

PART NUMBERS

204-011-401-5      204-011-401-9

204-011-401-7      204-011-401-11

TM 55-1615-226-40, 30 August 1974, is changed as follows:

1. Cover title is changed as shown above.
2. Remove and insert pages as indicated below.

	Remove pages	Insert pages
Table of Contents	i	i
Section I	1-1 and 1-2	1-1 and 1-2
Section II	2-1 thru 2-6 2-13 thru 2-15	2-1 thru 2-6 2-13 thru 2-15
Appendix B	B-1 thru B-4	B-1

3. New or changed text material is indicated by a vertical bar in the margin. An illustration change is indicated by a miniature pointing hand.

4. Retain this sheet in front of manual for reference purposes.

By Order of the Secretary: Army:

Official:  
**PAUL T. SMITH**  
 Major General, United States Army  
 The Adjutant General

**RED C. WEI**  
 General, United States Army,  
 Chief of Staff

DISTRIBUTION:

To be distributed in accordance with DA Form 12-31 Direct and General Support Maintenance Requirements for UH-1B, UH-1C/M and UH-1D/H aircraft.





CHANGE }  
No. 1 }

HEADQUARTERS  
DEPARTMENT OF THE ARMY  
WASHINGTON, D.C., 7 January 1975

GS Maintenance Manual  
Including Repair Parts and Special Tools List

SCISSORS AND SLEEVE ASSEMBLY

PART NUMBERS

204-011-401-5      204-011-401-9  
204-011-401-7      204-011-401-11

TM 55-1615-226-40, 30 August 1974, is changed as follows:

1. Remove and insert pages as indicated below.

	Remove pages	Insert pages
Section II	<del>2-3</del> and 2-4	<del>2-3</del> thru 2-4A/2-4B

2. New or changed text material is indicated by a vertical bar in the margin. An illustration change is indicated by a miniature pointing hand.

3. Retain this sheet in front of manual for reference purposes.

By Order of the Secretary of the Army:

Official:

**VERNE L. BOWERS**

*Major General, United States Army  
The Adjutant General*

**FRED C. WEYAND**

*General, United States Army  
Chief of Staff*

DISTRIBUTION:

To be distributed in accordance with DA Form 12-31 (qty rqr block nos. 344, 35, and 354, cumulative for all blocks) Direct and General Support Maintenance Requirements for UH-1B, UH-1C, UH-1D and LH aircraft.



TABLE OF CONTENTS

Section I INTRODUCTION ..... 1-1

    1-1. General Information ..... 1-1

    1-3. Reporting of Errors ..... 1-1

    1-5. Quality Control Personnel ..... 1-1

    1-7. Purpose of the Equipment ..... 1-1

    1-9. Equipment Records ..... 1-1

    1-11. Description and Leading Particulars ..... 1-1

    1-13. Test Equipment, Special Tools, and Materials ..... 1-1

    1-15. Consumable Materials ..... 1-2

II ITEM MAINTENANCE ..... 2-1

    2-1. Disassembly ..... 2-1

    2-11. Cleaning ..... 2-4

    2-14. Inspection After Cleaning ..... 2-4

    2-21. Repair and Replacement ..... 2-7

    2-28. Lubrication ..... 2-11

    2-30. Modification Data ..... 2-13

    2-31. Reassembly ..... 2-14

    2-36. Painting Requirements ..... 2-15

    2-39. Final Reassembly (Not Applicable) ..... 2-15

III FINAL TEST PROCEDURES (Not Applicable) ..... 3-1

IV PRESERVATION, PACKING, PACKING AND MARKING REQUIREMENTS . . . . 4-1

APPENDIX A REFERENCES ..... A-1

APPENDIX B REPAIR PARTS AND SPECIAL TOOLS LIST (Not Applicable) . . . . B-1



## SECTION I. INTRODUCTION

### 1-1. General Information.

1-2. This technical manual contains instructions for scissors and sleeve assembly, part number 204-011-401-11. (figure 1-1) manufactured by Bell Helicopter Company (FMC 97499), Fort Worth, Texas. Sections I through IV of this technical manual contain instructions for part number 204-011-401-11. Overhaul instructions for additional scissors and sleeve assemblies part number, 204-011-401-1-7 and 1-9 is provided in section V by the use of difference data sheets.

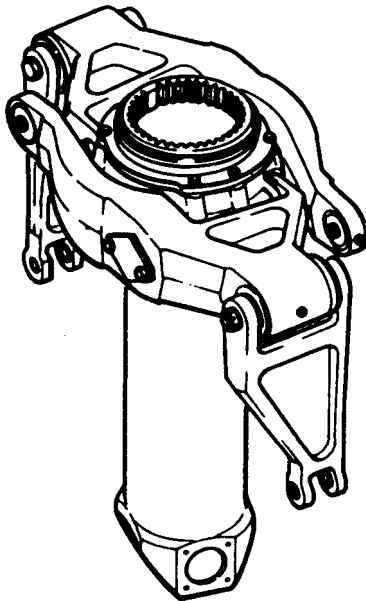

Figure 1-1. Scissors and sleeve assembly (typical)

### 1-3. Reporting Of Errors.

1-4. Report of errors, omissions and recommenda-

tions for improving this publication by the individual user is encouraged. Reports should be submitted on DA Form 2028 (Recommended Changes to DA Publications) and forwarded direct to Commander, U.S. Army Aviation Systems Command, ATTN: AMSAV-MC, 4300 Goodfellow Blvd., St. Louis, Missouri 63120-1798.

### 1-5. Quality Control Personnel.

1-6. Quality control personnel shall ensure complete compliance with quality program and/or inspection system requirements specified in the contract and this manual. Any deviations from the established requirements shall be approved by the contracting officer or his designated representative.

### 1-7. Purpose Of The Equipment.

1-8. The purpose of the scissors and sleeve assembly is to transmit cyclic and collective control to the main rotor through a system of linkages.

### 1-9. Equipment Records.

1-10. The Army equipment record system and procedures established in DA PAM 738-751 apply to this equipment. The applicable forms as required by DA PAM 738-751 shall be used.

### 1-11. Description And Leading Particulars.

1-12. The scissors and sleeve assembly operates in conjunction with the swashplate. The collective sleeve encircles the mast at the top of the transmission. Movement of the cyclic stick actuates linkage transmitting cyclic and collective control to the main rotor. The scissors and sleeve assembly consists of collective sleeve assembly, scissors assembly, and drive link assembly and their components.

### 1-13. Test Equipment, Special Tools, And Materials.

1-14. Special test equipment is not required to perform the procedures in this manual. Special tools required to perform the procedures in this manual are listed in table 1-1 and in TM 55-1520-210-23P.

Table 1-1. Special Tools and Test Equipment

FIGURE	NOMENCLATURE	PART NUMBER
none	Wrench	T101493
none	support	T101369
none	Ram Adapter	T101382
none	Wrench	T101392
none	Bar	T101424

**1-15. Consumable Materials.**

1-16. The consumable materials required to perform the procedures in this manual are listed in table 1-2.

Table 1-2. Consumable Material

ITEM NUMBER	NOMENCLATURE	TYPE OR GRADE	MILITARY SPECIFICATION
1	Dry Cleaning Solvent	Type II	PP-D-680
2	Aluminum Oxide and Silicone Carbide Abrasive	Type I	P-C-451
3	Crocus Cloth, Abrasive		P-C-458
4	Brush Plating		MIL-STD-865
5	Lubricating Oil, General Purpose Low, temperature		MIL-L-7870A
6	Hot Application, Petrolatum Corrosion Preventive Compound	class 3	MIL-C-11796
7	Grease, Aircraft, Helicopter Oscillating, Bearing		MIL-G-81322
8	Sealing locking, and Retaining Compound	AV(10-10)	MIL-S-22473
9	Brush Alodine	N/A	ME-C-5541
10	Zinc Chromate Primer	Technical	MIL-P-8585
11	Methyl-Ethyl-Ketone	Technical	T-T-M-261
12	Locquic, Primer	Grade Q	MIL-S-22473
13	Acrylic Lacquer Fed Std 595 Color No. 17038 (Gloss Black)		
14	pressure sensitive tape 3M Scotchcal, No. 3655 (Black) or equivalent		
15	Retaining compound	Grade CV	MIL-S-22473

**1-17. Flight Safety Parts.**

1-18. The following parts are designated as Flight Safety Parts:

- Scissors Assembly           Item 6, fig. 2-1
- Collective Sleeve           Item 45
- Link Assembly                Item 5
- Hub Assembly                 Item 37
- Plate Set                     Item 33
- Retainer Nut                 Item 36
- Collective Sleeve Bearing
- Retention Nut                Item 41

**0-2 Special Inspection** The following evaluation criteria will be followed for scissors and sleeve assemblies that have been subject to accident or unusual incident.

a. Carefully inspect assembly component visually for any apparent damage or abnormal appearance. Obvious defects which are cause to scrap entire assembly are

- (1) Severe bind in any pivot joint.
- (2) Severe bind between hub and sleeve,

b. Any detail part within the scissors and sleeve assembly which has sustained surface damage shall be subject to surface damage inspection and repair as outlined in this technical manual. Surface damage in excess of overhaul manual limits shall require scrapping only damaged parts.

c. An unworn bolt shall fit freely through bushings in the drive link. Any bind is cause to scrap drive link.

d. Straight edge check cylinder portion of collective sleeve for deformation. Warpage exceeding .005 inch in a 5 inch length is reason to scrap sleeve.

e. All machined flat surfaces surrounding lugs, holes, and bushings of entire assembly should be straight edge checked for deformation. Deviations from flat exceeding .002 inch will require scrapping part.

f. Proceed with normal overhaul in accordance with applicable instructions, including magnoflux and zygo is required therein.

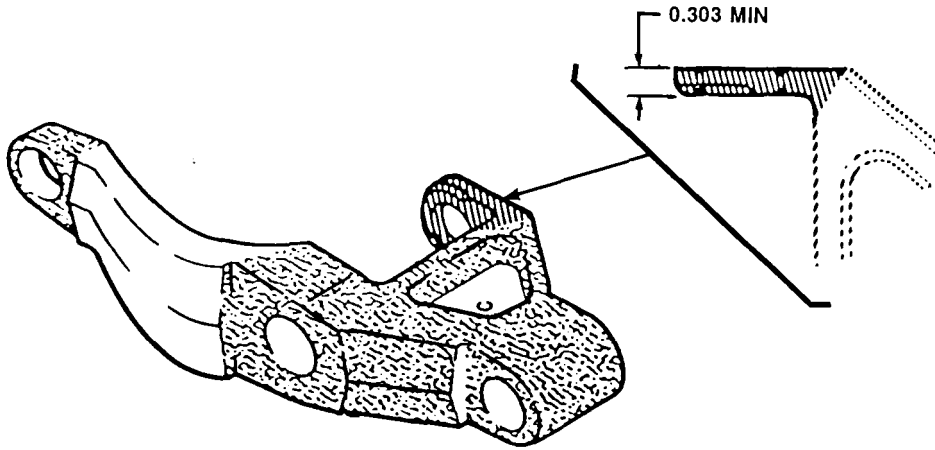

Figure 2-1.1 Scissors Assembly



Section II. ITEM MAINTENANCE

2-1. Disassembly

2-2. When overhauling the scissors and sleeve assembly, disassemble only to the extent necessary for cleaning, inspection, and replacement of defective components. (See figure 2-1.)

CAUTION

Use Adequate protection to prevent damage to collective sleeve during disassembly and reassembly operations.

2-3. Scissor and Sleeve Assembly

2-4. Disassembly scissors and sleeve assembly as follows:

- a. Remove cotter pin (1, figure 2-1), nut (2) and washer (3) from pivot bolt (4). remove drive link (5) from scissors (6).

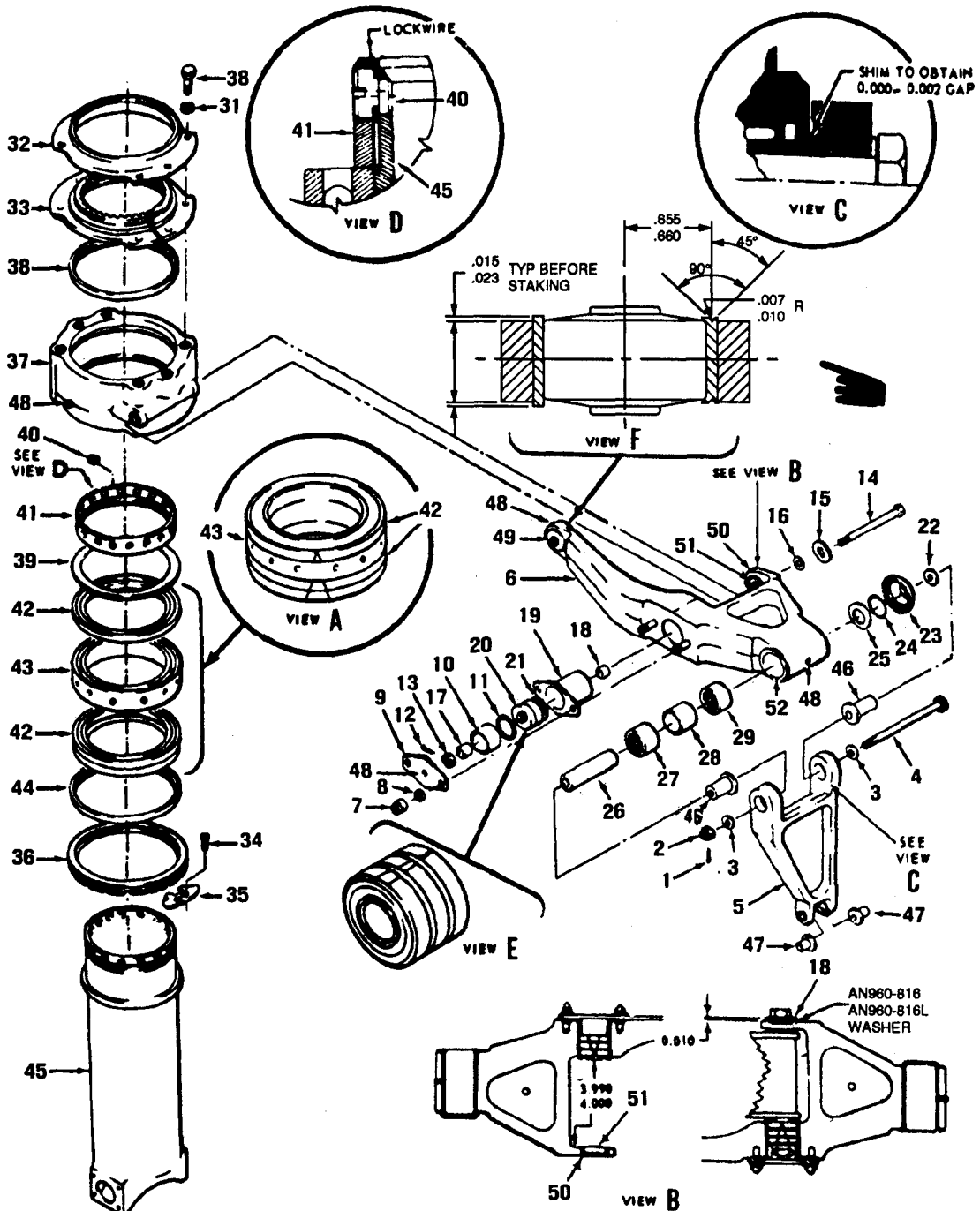

Figure 2-1. Scissors and Sleeve Assembly - Exploded View

Figure & Index No.	Part Na	Description	Qty Per Assy	Usable on code
2-1-	204-011401-5	SCISSORS AND SLEEVE ASSEMBLY . . . . .		D
	204-011-401-7	SCISSORS AND SLEEVE ASSEMBLY . . . . .		C
	204-011401-9	SCISSORS AND SLEEVE ASSEMBLY . . . . .		3
	204-011-401-11	SCISSORS AND SLEEVE ASSEMBLY . . . . .		A
- 1	MS24665-302	PIN, Cotter . . . . .	4	
- 2	AN320-8	NUT . . . . .	4	
- 3	AN960PD816	WASHER . . . . .	AR	
- 4	NAS464-8-69	BOLT . . . . .	2	CD
	NAS464P8-69	BOLT . . . . .	2	AB
- 5	204-01147-1	DRIVE LINK Assembly . . . . .	2	
- 6	204-011-406-5	SCISSORS, Assembly . . . . .	2	CD
	204-011-406-9	SCISSORS, Assembly . . . . .	2	AB
- 7	MS21045C3	NUT . . . . .	2	
- 8	AN960PD10	WASHER . . . . .	4	
- 9	204-010-456-3	PLATE, Cover . . . . .	2	
- 10	204-010-455-3	SPACER,Pivot Bearing . . . . .	2	
- 11	120-045-32-29	SHIM . . . . .	2	
- 12	MS24665-302	PIN, Cotter . . . . .	4	
- 13	AN 320-8	NUT . . . . .	4	
- 14	NAS464-8-90	BOLT . . . . .	2	CD
	NAS464P8-90	BOLT . . . . .	2	AB
- 15	204-011-459-1	WASHER, Saftey . . . . .	2	AB
- 16	AN960-816	WASHER . . . . .	4	AB
	AN960-816L	WASHER (Replaces AN960-816 when required by installation procedures) . . . . .	4	AB
- 17	NAS434HT8-21	SPACER . . . . .	2	CD
	NAS434HT8-18	SPACER . . . . .	2	AB
- 18	204-011-448-1	SPACER . . . . .	2	
- 19	204-010-453-3	LINER, Pivot Bearing . . . . .	2	
- 20	204-011-412-1	BEARING SET . . . . .	2	
- 21	120-045-3529	SHIM . . . . .	AR	
- 22	120-04527-17	SHIM . . . . .	AR	
- 23	204-011421-1	HOUSING, Assembly . . . . .	2	
- 24	71X6223	SEAL . . . . .	1	
- 25	204-011.420-1	WASHER, Thrust . . . . .	2	
- 26	204-01141-3	RACE, Inner . . . . .	2	
- 27	204-011418-1	BEARING . . . . .	2	
- 28	204-011422-1	SPACER . . . . .	2	
- 29	204-011-419-1	BEARING . . . . .	2	
- 30	AN4H5A	BOLT . . . . .	6	
- 31	AN960PD416	WASHER . . . . .	6	
- 32	204-010-445-1	FLANGE . . . . .	1	
- 33	204-01047S11	PLATE (Use with 204-011401-9, Scissors Sleeve Assembly) . . . . .	1	BCD
	204-010-479-17	PLATE (Use with 204-011-401-11, Scissors and Sleeve Assembly) . . . . .	1	A
- 34	MS35276-26	SCREW . . . . .	2	
- 35	204-011-454-1	PLATE, Lock . . . . .	1	

Figure & Index No.	Part No.	Description	Qty Per Assy	Usable On Code
-36	204-010-437-5	NUT, Assembly, Lower Retaining . . . . .	1	
-37	204-011-405-5	HUB, Assembly . . . . .	1	D
	204-011-405-9	HUB, Assembly . . . . .	1	ABC
-38	204-010-428-1	SEAL . . . . .	2	
2-1-39	204-011-411-1	RING, Spacer . . . . .	1	
-40	204-011-453-1	PIN . . . . .	1	
-41	204-010-420-1	NUT, Bearing Retaining . . . . .	1	
-42	204-011-409-1	RING, Bearing Set . . . . .	1	
-43	204-011-410-1	SPACER SET . . . . .	1	
-44	204-010-428-1	SEAL, Plain Encased . . . . .	1	
-45	204-011-408-1	SLEEVE, Collective . . . . .	1	D
	204-011-408-3	SLEEVE, Collective . . . . .	1	ABC
-46	22-010-31-35-41	BUSHING . . . . .	4	
-47	22-007-19-27-1	BUSHING . . . . .	4	
-48	NAS516-1	FITTING, Lubrication . . . . .	2	
-49	BR5R	BEARING, Staked . . . . .	2	
-50	204-011-456-1	LINER . . . . .	2	
-51	MS20201KP8A	BEARING . . . . .	2	
	AN201KP8A	BEARING (Used on 204-011-406-13 Scissors Assembly . . . . .	1	
-52	204-011-413-1	LINER . . . . .	2	

b. Remove the opposite drive link by the same procedure.

c. Remove nuts(7), washers (8) and cover plate (9)from scissors (6).

d. Remove spacer (10)and shim (11). Remove cotter pin (12) and nut (13) from bolt (14). Remove bolt, spacers (17 and 18) and washers (15 and 16). Remove scissors from hub (37).

**NOTE**

*Use wire or tape to secure bearing (51) in scissors (6).*

e. Remove the opposite scissors by the same procedure.

**2-5. Drive Link**

2-6. Disassembly of drive link assembly is not required except when necessary to replace components requiring repair or replacement.

**2-7. Scissors.**

2-8. Disassemble scissors as follows:

a. Remove liner (19, figure 2-1) from scissors (6). Use T101424 bar to press out bearing set (20) and shim (21) from liner (19).

b. Remove shim (22), housing (23) with seal (71X6223)(24), thrust washer (25) and inner race (26).

c. Additional disassembly of scissors is not required except when necessary to replace components requiring repair or replacement.

d. When necessary, use T101424 bar to press out bearings (27 and 29) and spacer (28).

**2-9. Hub And Collective Sleeve.**

2-10. Disassemble hub and collective sleeve as follows :

a. Cut and remove lockwire. Remove six bolts (30, figure 2-1), washers (31), flange (32) and plate set (33) from top of collective sleeve hub (37). Install wrench T101392 on hub with two bolts. Invert assembly and: ecur wrench in a vise.

b. Cut and remove lockwire. Remove two screws (34) and lock plate (35). Using wrench T101493, turn lower retaining nut (36) out of hub (37), allowing nut to remain at lower end of sleeve. Remove assembly from vise and remove tools.

c. Place assembly upright on a press with suitable support under hub. Insert smallest end of ram adapter T101382 in top of sleeve (45) and press sleeve assembly out of hub (37).

d. Remove seal (38) from hub. Remove spacer ring (39) from bearing stack.

e. Cut and remove lockwire and remove pin (40,

figure 2-1). Install Wrench T101392 with pins engaged in holes of nut (41). Insert bar T101424 in holes at lower end of sleeve and hold to prevent sleeve from turning while removing left-hand threaded nut. Remove tools.

**CAUTION**

**Bearings must clear support during pressing operations.**

f. Place sleeve assembly on a press with support halves T101369 under inner race of lower bearing. Remove bearing and spacer sets (42 and 43) by pressing out sleeve (45) with T101382 adapter. Remove lower retaining nut (36) from sleeve. Remove seal (44) using ram adapter T101382.

**2-11. Cleaning**

**2-12. Drive Link, Scissors, Hub, And Collective Sleeve Assemblies.**

2-13. Clean the drive link, scissors, hub, and collective sleeve assemblies using solvent (item 1, table 1-2) and dry using compressed air.

**2-14. Inspection After Cleaning.**

*NOTE*

*Inspection limits and torque values for various components of the scissors and sleeve assembly may be easily referenced in figure 2-2.*

**2-15. Drive Link.**

2-16. Inspect drive link as follows:

a. Perform nondestructive test in accordance with table 2-1.

b. Inspect bushing (47, figure 2-1) in trunnion tang of drive link (5), for excessive wear.

ID of bushing must not exceed 0.3140 inch. Inspect for scoring of inside surface of bushing. Check dimension between trunnion tangs and between bushings. If dimension between trunnion tangs is greater than 1.003 inch, scrap drive link. If dimension between bushings is greater than .880 inch, replace bushings.

c. Inspect bushings (46) in scissors tang of drive link (5), for excessive wear. Allowable ID of bushings must not exceed 0.5014 inch. Inspect for scoring of inside surface of bushing.

d. Inspect drive link (5) for mechanical or corrosion damage.

(1) Mechanical damage must not exceed 0.010-inch depth in area within 1.25 inches of centerline of either the trunnion or the scissors attachment tangs.

(2) Corrosion damage must not exceed 0.005-inch depth in area within 1.25 inches of the trunnion or the scissors attachment tangs.

(3) Mechanical damage must not exceed 0.035 inch in depth in ail areas of drive link other than specified in (1) above.

(4) Corrosion damage must not exceed 0.017 inch in depth in all areas of drive link other than specified in (2) above.

(5) Mechanical or comosion damage in any one area must not exceed 0.25 square inch in area or 0.75 in any one length.

(6) Mechanical damage to surfaces surrounding a hole within 1.5 times radius of that hole must not exceed 0.010 inch in depth.

(7) Corrosion damage to surfaces surrounding a hole within 1.5 times radius of that hole must not exceed 0.005 inch in depth.

(8) Score marks on inside surface of holes or bushings must not exceed 0.002 inch.

**TABLE 2-1. NONDESTRUCTIVE INSPECTION TEST DATA (INSPECT FOR CRACKS)**

Figure And Index Number	Part No.	Nomenclature	Test	Longitudinal (With Coil DC)	Circular (With Heads DC)
2-1					
5.	204-011-407	Drive Link	F		
6.	204-011-406	Scissors Assembly	F		
33.	204-010-479	Plate Set	F		
36.	204-010-437	Nut (Lower Retaining)	M	8,000 Amp Turns*	2,000 Amps,
37.	204-011405	Hub Assembly	M	15,000 Amp Turns* Rotate 90°-2 shots	2500 Amps.-1-1/2" dia Central Conductor
41.	204-010-420	Nut (L.H. Threaded)	M	8,000 Amp Turns* Rotate 90°-2 shots	2,250 Amps.-1-1/2" dia Central Conductor
26.	204-011441-3	Race, inner	M	4,500 Amps	800-1,000 Amps

**MAGNETIC PARTICLE INSPECTION**

The following parts shall be inspected with the wet fluorescent process using the continuous method of magnetization in accordance with MIL-I-6868. Inspect all surfaces. No cracks allowed.

Figure 2-1 Item #	Nomenclature	Shot and Amperage
26	Inner Race	Use a 1/2" central conductor. Make one (1) shot at 100 amps, remove and inspect I.D. and O.D. of part.
36	Nut, Lower Retaining	Use a 3" central conductor. Make one (1) shot at 2000 amps and inspect part.
37	Hub Assembly	Use a 3" central conductor. Make 2 equally spaced shots (180° apart) at 3500 amps and inspect I.D. and O.D. Make a coil shot at 10,000 amp turns, remove from coil to inspect I.D. and O.D.
41	Nut, Bearing Retainer	Use a 2" central conductor. Make one (1) shot at 600 amps and inspect part.
45	Collective Sleeve	Use a 2" central conductor. Make 3 equally spaced shots (120° apart) at 500 amps. Make a coil shot at 3000 amp turns, remove from coil to inspect I.D. and O.D.

**TABLE 2-1. NONDESTRUCTIVE INSPECTION TEST DATA (INSPECT FOR CRACKS)**

---

**PENETRANT INSPECTION**

The following parts are to be inspected with fluorescent penetrant inspection in accordance with ML-I-6866 using a penetrant of a minimum sensitivity equal to ML-I-25135, Group VI. Inspect all surfaces. No cracks allowed.

---

Figure 2-1	Nomenclature
5	Drive Link
6	Scissors Assembly
33	Plate Set

---

Figure And Index Number	Part No.	Nomenclature	Test	Longitudinal (With Coil DC)	Circular (With Heads DC)
-------------------------	----------	--------------	------	-----------------------------	--------------------------

45.	204-011-408	Collective Sleeve	M	10,000 Amp Turns* Use two shots for complete coverage.	2,000 Amps-1-1/2° Central Conductor
-----	-------------	-------------------	---	---	--

## TEST CODE

M = Magnetic Particle Inspection Per MIL-I-6868

F = Fluorescent Penetrant Inspection Per MIL-I-6866

## NOTE

*Divide Amp turns specified by number of turns in coil of equipment used, to determine amperage to be applied to part.*

**2-17. Scissors Assembly.**

2-18. Inspect scissors assembly as follows:

**CAUTION**

**Take necessary precaution to protect any bearings not removed from assembly, from contamination by penetrant during non-destructive inspection test.**

a. Perform nondestructive inspection in accordance with table 2-1.

b. Inspect inner race (26, figure 2-1) for flaked or spalled area, brinelling, wear bands, scratches, or defects on contact surface.

c. Inspect bearings (27 and 29) for dented seals or shields, broken, cracked or spalled, flaked, pitted, scored, etched areas, rust or corrosion, wear bands on rollers, or excessive looseness due to wear.

d. Inspect bearings for evidence of overheating.

**NOTE**

*Light gray lubrication stains are acceptable, provided the surface is not physically affected.*

e. Inspect thrust washer (25) for wear or damage.

f. Inspect housing (23) and seal (71X6223) (24) for wear and damage.

g. Inspect spacers (18 and 19, figure 2-1) for wear and damage, pitting, scratches, rust corrosion, and cracks.

h. Visually inspect spacer (28, figure 2-1) in scissors for damage.

i. Inspect bearing set (20) for damaged seals or shields, smoothness and freedom of operation, and excessive looseness of bearings, end liner (19) for wear and damage.

j. Inspect bearings (49 and 51) for freedom of movement and smoothness of operation. Inspect

bearing (49) and liner for looseness. Any looseness will require removal of liner and checking bearing (46). Egging of the hole not to exceed 0.001 for 30 degrees. Inspect bearing (51) and liner (50) for looseness. Any looseness will require removal of the liner (50) and checking the mating hole. Egging shall not exceed 0.0005 for 30 degrees.

k. Inspect scissors (6) for mechanical or corrosion damage.

(1) Mechanical damage must not exceed 0.010 inch in depth in area from the centerline of the pivot bore to the extremity of the drive link attachment lug. This damage is not to violate minimum dimension shown in figure 2-1.1.

(2) Corrosion damage must not exceed 0.005 inch in depth from the centerline of the pivot bore to the extremity of the drive attachment lug. This damage is not to violate minimum dimension shown in figure 2-1.1.

(3) Mechanical damage to surfaces within 0.5 inch of any hole must not exceed 0.010 inch in depth from the centerline of the pivot bore to the extremity at the drive link attachment lug, and repair area must not exceed 25 percent of the area within 0.5 inch of any hole.

(4) Corrosion damage to surfaces within 0.5 inch of any hole must not exceed 0.005 inch in depth from the centerline of the pivot bore to the extremity of the drive link attachment lug, and repair area must not exceed 25 percent of the area within 0.5 inch at any hole.

(5) Mechanical damage must not exceed 0.035 inch in depth in all areas of scissors other than specified in (1) and (3) above,

(6) Corrosion damage must not exceed 0.017 inch in depth in all other areas of scissors other than specified in steps (2) and (4) above.

(7) Mechanical or corrosion damage in any one area must not exceed 0.25 square inch in area or 0.75 inch in any one length.

(8) Score marks on the inside surface of holes and bushings must not exceed 0.002 inch.

## 2-19. Hub And Collective Sleeve.

2-20. Inspect hub and collective sleeve as follows:

a. Perform nondestructive inspection of hub in accordance with table 2-1.

b. Inspect hub bolt hole ID for wear. Wear limit shall not exceed 0.5015 inch.

c. Inspect hub-bearing bore ID for wear. Wear limit shall not exceed 5.2520 inches.

d. Inspect hub for mechanical or corrosion damage.

(1) Mechanical or corrosion damage to thread inside hub.

(2) Mechanical damage shall not exceed 0.010 inch in depth on the flat surfaces at the end of scissors attachment lugs and the surrounding surfaces within 0.60 inch of these ends

(3) Mechanical damage shall not exceed 0.010 inch in depth on the 0.4995-inch bore surface

(4) Corrosion damage shall not exceed 0.005 inch in depth on the flat surfaces at the end of the scissors attachment lugs on the surrounding surfaces within 0.60 inch of these ends

(5) Corrosion damage shall not exceed 0.005 inch in depth on the 0.4995-inch bore surface.

(6) Mechanical damage shall not exceed 0.035 inch in depth in all areas of hub other than specified in (1) (2), and (3) above.

(7) Corrosion damage shall not exceed 0.017 inch in depth.

(8) Damage in any one area shall not exceed 0.25 square inch in area or 0.75 inch in any one length.

(9) Mechanical damage to surfaces surrounding a hole, within a distance of 1.5 times the radius of that hole shall not exceed 0.010 inch in depth.

(10) Corrosion damage to surfaces surrounding a hole within 1.5 times radius of that hole shall not exceed 0.005 inch in depth.

(11) Inspect hub bolt hole for scoring. Score marks inside the bolt hole shall not exceed 0.002 inch.

e. Perform nondestructive inspection of collective sleeve, in accordance with table 2-1.

f. Inspect sleeve bearing seat for wear. OD of bearing seat shall not be less than 4.2480 inches

g. Inspect sleeve for damage to the 4-1/4-16 UN-2A threads at upper end of sleeve

h. Inspect sleeve for damage to 10-32 NF3B threads of the eight bolt holes at the base of the sleeve

i. Inspect sleeve for mechanical or corrosion damage.

(1) Mechanical damage shall not exceed 0.01-inch depth to the flat surfaces surrounding the 1.500 inch diameter holes and the inside and outside of the 4.080-inch OD cylindrical surfaces

(2) Corrosion damage shall not exceed 0.005 inch in depth to the flat surfaces surrounding the 1.50-inch diameter holes and the inside and outside of the 4.080-inch OD cylindrical surfaces

(3) Mechanical damage shall not exceed 0.035 inch in depth in all areas at the sleeve other than specified in (1) above

(4) Corrosion damage shall not exceed 0.017 inch in depth in all areas of the sleeve other than specified in (2) above.

j. Visually inspect flange (32, figure 2-1) for wear or damage.

k. Inspect plate set (33), using nondestructive test as outlined in table 2-1. Inspect teeth of spline for damage.

l. Visually inspect lock plate (35) for wear or damage.

m. Inspect nut (36) using nondestructive test in accordance with table 2-1. Inspect threads for damage.

n. Visually inspect spacer ring (39) for wear or damage, warpage, pitting, scratches corrosion and cracks.

o. Inspect pin (40) for wear or damage.

p. Inspect nut (41) using nondestructive test in accordance with table 2-1. Inspect threads for damage.

q. Inspect bearing set (42) for damaged seals or shields smoothness and freedom of operation, and excessive looseness.

### NOTE

*Check bearings for smoothness of operation prior to disassembly of sleeve assembly. Visually inspect ball bearings and races on bench under strong light.*



r. Visually inspect spacer set (43) for wear and damage, pitting, scratches and rust.

## 2-21. Repair And Replacement

### 2-22. Drive Link

2-23. Repair or replace drive link components in accordance with the following instructions.

a. Replace drive link (5, figure 2-1) if found defective by fluorescent penetrant inspection.

b. Replace bushing (47, figure 2-1) in trunnion tang of drive link (5) if ID exceeds 0.3140 inch. Replace bushing if scoring or damage to inside of surface bushing exceeds 0.002 inch.

(1) Coat mating surfaces with primer (item 10, table 1-2) and press new bushing into trunnion tang.

(2) Line ream two bushings 0.3120 to 0.3125 after installation.

c. Replace bushing (46) in scissors tang of drive link (5) if ID of bushing exceeds 0.5014 or if scoring or damage to inner surface of bushing exceeds 0.002 inch.

(1) Coat mating surfaces with primer (item 10, table 1-2) and press new bushing into scissors tang.

(2) Line ream bushing to 0.4995 to 0.500 after installation.

d. Replace pivot bolt (4).

e. Replace drive link (5) if mechanical damage exceeds 0.010 inch in depth in area within 1.25 inches of centerline of the trunnion or the scissors attachment tangs.

f. Replace drive link if corrosion damage exceeds 0.005 inch in depth in area within 1.25 inches of either scissors or trunnion attachment tangs.

g. Replace drive link if mechanical damage in areas other than specified in step e above exceeds 0.035 inch in depth.

h. Replace drive link if corrosion damage in any area other than specified in step f above exceeds 0.017 inch in depth.

i. Replace drive link if damage in any one area exceeds 0.25 square inch in area or 0.75 inch in any one length or if full depth repair exceeds these limits.

#### NOTE

*The transitional region wherein the repair is blended into surrounding*

*surface may be outside these limits.*

j. Replace drive link if mechanical damage to surfaces surrounding a hole within 1.5 times radius of that hole exceeds 0.010 inch in depth.

k. Replace drive link if corrosion damage to surfaces surrounding a hole within 1.5 times radius of that hole exceeds 0.005 inch in depth.

l. Mechanical damage to drive link except for area within 1.25 inches of the centerline of the trunnion and scissors attachment holes may be polished out if damage does not exceed 0.035 inch in depth before or after repair. The damage or the full depth repair in any one area shall not exceed 0.25 square inch area nor 0.75 inch in any one length. The area of blending repair into surrounding surface may be outside these limits.

m. Corrosion damage to drive link except for area within 1.25 inches of the centerline of the trunnion and scissors attachment holes may be polished out if damage does not exceed 0.017 inch in depth. The damage or the full length repair in any one area shall not exceed 0.25 square inch in area or 0.75 inch in any one length. The area of blending repair into surrounding surfaces may lie outside these limits.

n. Score marks on the inside surface of holes and bushings may be polished out if the damage is 0.002 inch or less.

#### NOTE

*Polish out mechanical and corrosion damage blending the repair smoothly into the surrounding surface.*

*Polish out mechanical damage only to a depth sufficient to remove traces of the damage. Polish out corrosion damage to twice to the depth of the pit.*

*Do not remove more material than necessary to effect repair as described. Do not use grinding wheel.*

*Polish out mechanical or corrosion damage with fine to medium grade abrasive cloth (item 2, table 1-2) or fine India stone,*

*and final polish to a scratch-free finish with abrasive cloth (item 3, table 1-2).*

*Cadmium plating removed by repair should be reapplied by brush cadmium plating (item 4, table 1-2). Repair areas on aluminum anodized surfaces with brush alodine (item 9, table 1-2.)*

## 2-24. Scissors Assembly.

2-25. Replace components of the scissors assembly as follows:

a. Scissors (6, figure 2-1) shall be replaced if found to be defective after Fluorescent Penetrant inspection or if visual inspection indicates the scissors have failed to meet the inspection requirements outlined in paragraph 2-18 step k.

b. Replace inner race (26) bearings (27 and 29) spacer (28), thrust washer (25) and housing (23), with seal (71 x 6223) (24) installed if these items fail to meet inspection requirements,

c. Replace spacer (21), bearing set (20), and liner (19) if these items fail to meet inspection requirements.

### NOTE

*Bearing set (20) shall be replaced as a matched set only. Do not replace individual bearings.*

d. Replace bearing (27), spacer (28), and bearing (29) as follows:

(1) Clean bore of liner (52, figure 2-1) thoroughly with drycleaning solvent (item 1, table 1-2). Endure all adhesive, dirt, and grease is removed.

### NOTE

*Exercise extreme care when removing adhesive from bore of liner. Do not enlarge bore or change bore dimensions in any way.*

(2) After bore has been thoroughly cleaned coat bore of liner (52) with oil (item 5, table 1-2).

(3) Use bar, T101424, to press bearing (29) (without seal) spacer (28) and bearing (27) (with seal on outer side) into liner (52, figure 2-1).

(4) Insert inner race (26) through bearings (27 and 29) and spacer (28).

e. Replace bearing (51, figure 2-1) (MS202011KP8A or AN201KP8A) if allowable play of 0.010 inch axial and/or 0.012 inch radial is exceeded.

f. Maximum allowable wear to sleeve (50, figure 2-1) is 0.0025 inch. If ID is greater than 1.1285 inch replace sleeve as follows:

(1) Press out the sleeve.

(2) Clean bore in scissors with drycleaning solvent (item 1, table 1-2). Ensure all adhesive, dirt, and grease is removed.

### NOTE

*Exercise extreme care when removing adhesive from bore of scissors. Do not enlarge bore or change bore dimensions in any way.*

(3) Coat outer surface of sleeve (50) and bore of scissors with retaining compound (item 8, table 1-2).

(4) Press sleeve (50) into scissors.

### NOTE

*Support opposite side of scissors leg during pressing operation to prevent damage to scissors.*

(5) Clean any excessive retaining compound from sleeve and leg of scissors.

(6) Ensure sleeve (50) is flush with inner surface of scissors leg.

(7) Allow retaining compound to cure in accordance with the following standards.

50 percent full strength in 2 hours at 75°F,

80 percent full strength in 6 hours at 75°F,

100 percent full strength in 12 hours at 75°F.

100 percent full strength in 10 minutes at 212°F, or

100 percent full strength in 5 minutes at 350°F.

(8) Push bearing (51) into sleeve (50).

g. Replace bearing (49) (BR5R) if allowable play of 0.010 inch axial and/or 0.007 inch radial is exceeded.

h. Replace bearing as follows:

**CAUTION*****Use suitable support under tang of scissors to prevent damage during pressing operations.***

(1) Press bearing (49) and liner out of scissors level (6).

(2) Clean scissors lever using solvent (item 11, table 1-2).

(3) Apply primer (item 10, table 1-2) to mating surfaces of new liner and scissors lever.

(4) Press liner into scissors lever.

(5) Remove lubrication fitting (48) from scissors lever.

(6) Using lubrication fitting hole as a guide, drill one 0.092- to 0.098-inch diameter hole through liner.

(7) Ream liner 1.2488- to 1.2493-inch diameter.

(8) Clean liner thoroughly using compressed air.

(9) Apply primer (item 10, table 1-2) to mating surfaces of new bearing (49) and liner.

(10) Press bearing (49) into liner.

(11) Ring stake sleeve around bearing at both sides. See view F, figure 2-1. Test after installation by applying proof load of 500 pounds in both directions. Apply load to outer race only. Do not apply load to inner race. This is a sign-off inspection point.

*i.* Score marks on the inside surface of holes and bushings may be polished out if damage is 0.002 inch or less.

**NOTE**

*Polish out mechanical and corrosion damage blending the repair smoothly into the surrounding surface.*

*Polish out mechanical damage only to a depth sufficient to remove traces of the damage. Polish out corrosion damage to twice the depth of the pit.*

*Do not remove more material than necessary to effect repair as described.*

*Do not use grinding wheel. Polish out mechanical or corrosion damage with fine to medium grade abrasive cloth (item 2, table 1-2) or fine India stone, and final polish to a scratch-free finish with crocus cloth (item 3, table 1-2).*

*Cadmium plating removed by repair should be reapplied by brush cadmium plating (item 4, table 1-2). Repair areas on aluminum anodized surfaces with brush alodine (item 9, table 1-2).*

**2-26. Hub and Collective Sleeve.**

2-27. Replace or repair components of the hub and collective sleeve as follows

*a.* Replace hub (37, figure 2-1) if found defective by magnetic particle inspection.

*b.* Replace hub if it fails to meet inspection requirements outlined in paragraphs 2-20b, c, and d.

*c.* Replace sleeve (45) if found defective by magnetic particle inspection.

*d.* Replace sleeve (45) if it fails to meet inspection requirements as outlined in paragraphs 2-20f, g, h, or i.

*e.* Replace plate set (33) if found to be defective by fluorescent penetrant inspection or if spline teeth are damaged.

*f.* Replace nut (36) if found to be defective by magnetic particle inspection or if threads are damaged.

*g.* Replace nut (41) if found to be defective by magnetic particle inspection or if threads are damaged.

*h.* Replace flange (32), lock plate (35), shoulder ring (39) pin (40) bearing seta (42) or spacer set (43) if they fail to meet inspection requirement. Bearings seta (42) should be replaced as matched sets only

*i.* Replace seals (38 and 44).

*j.* Repair mechanical damage to hub as follows:

**NOTE**

*Damage in any one area must not exceed 0.25*

*square inch in area or 0.75 inch in any one length The area wherein the repair is blended into the surrounding surface is not included in these limits.*

(1) Polish out mechanical damage not exceeding 0.010 inch in depth to hub on the flat surfaces at the end of the scissors attachment lugs and the surrounding surfaces within 0.60 inch of these ends. Damage shall not exceed 0.010 inch in depth after repair.

(2) Polish out mechanical damage on the 0.4995-inch bore surface not exceeding 0.010 inch in depth. Damage shall not exceed 0.010 inch in depth after repair.

(3) Polish out mechanical damage to hub in all areas of hub other than specified in steps j, (1) and (2) above. Damage shall not exceed 0.035 inch in depth after repair.

(4) Polish out mechanical damage not exceeding 0.010 inch in depth to the surfaces surrounding a hole within 1.5 times the radius of that hole. Damage shall not exceed 0.010 inch in depth after repair.

**NOTE**

*Polish out mechanical damage blending the repair smoothly into the surrounding surface.*

*Polish out mechanical damage only to a depth sufficient to remove traces of the damage.*

*Do not remove more material than necessary to effect repair as described. Do not use grinding wheel.*

*Polish out mechanical damage with fine to medium grade abrasive cloth (item 2, table 1-2) or fine India stone, and final polish to a scratch free finish with crocus cloth (item 8, table 1-2).*

*Cadmium plating removed by repair should be reapplied by brush cadmium plating, (item 4, table 1-2). Repair areas on aluminum anodized surface with brush alodine (item 9, table 1-2).*

k. Repair corrosion damage to hub as follows:

**NOTE**

*Damage in any one area must not exceed 0.25 square inch in area or 0.75 inch in any one length The area wherein the repair is blended into the surrounding surface is not included in these limits.*

(1) Polish out corrosion damage on the flat surfaces at the end of the scissors attachment lugs on the surrounding surfaces within 0.060 of these ends not exceeding 0.005 inch in depth. Damage shall not exceed 0.010 inch in depth after repair.

(2) Polish out corrosion damage on the 0.499-inch bore surface not to exceed 0.005 inch. Damage shall not exceed 0.010 inch after repair.

(3) Polish out corrosion damage to surfaces surrounding a hole within 1.5 times radius of that hole not to exceed 0.005 inch after repair.

(4) Corrosion damage in all other areas of hub other than specified in k, (1), (2) and (3) above shall not exceed 0.017-inch depth or 0.035 inch in depth after repair.

1. Repair mechanical damage to sleeve as follows:

**NOTE**

*Damage in any one area shall not exceed 0.25 square inch in area or 0.75 inch in any one length. The area wherein the repair is blended into the surrounding area is not included in these limits.*

(1) Polish out mechanical damage not exceeding 0.010 inch in depth to the flat surfaces surrounding the 1.500-inch diameter holes and the inside and outside of the 4.080-inch OD cylindrical surfaces. Damage shall not exceed 0.010 inch in depth after repair.

(2) Polish out mechanical damage in all areas of the sleeve other than those specified in 1, (1) above not exceeding 0.035 inch in depth. Damage shall not exceed 0.035 inch in depth after repair.

**NOTE**

*Polish out corrosion damage blending the repair smoothly into the surrounding surface.*

*Polish out corrosion damage to twice the depth of the*

*pit. Do not remove more material than necessary to effect repair as described. Do not use grinding wheel for repair.*

*Polish out corrosion damage with fine to medium grade abrasive cloth, (item 2, table 1-2) or fine India stone and final polish to a scratch-free finish with crocus cloth (item 3, table 1-2).*

*Cadmium plating removed by repair should be reapplied by brush plating (item 4, table 1-2). Repair areas on aluminum anodized surface with brush alodine (item 9, table 1-2).*

**m.** Repair corrosion damage to sleeve as follows

**NOTE**

*Damage in any one area must not exceed 0.25 square inch in area or 0.75 inch in any one length. The area wherein the repair is blended into the surrounding area is not included in these limits.*

(1) Polish out corrosion damage not exceeding 0.005 inch in depth to the flat surfaces surrounding the 1. MO-inch diameter holes and the inside and outside of the 4.080-inch OD cylindrical surfaces. Damage shall not exceed 0.010-inch depth after repair.

(2) Corrosion damage shall not exceed 0.017 inch in depth in all areas of the sleeve other than specified in step *m*, (1) above. Damage shall not exceed 0.035 inch in depth after repair.

**NOTE**

*Polish out corrosion damage blending the repair smoothly into the surrounding surface. Polish out corrosion damage to twice the depth of the grit. Do not remove more material than necessary to*

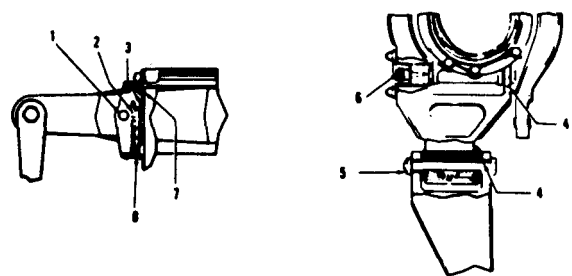

ITEM	NOMENCLATURE		MFG DIMENSION (INCHES)	REPLACE AT
1	HUB BOLT HOLE	ID	0.4886 0.5000	0.5015
2	HUB BEARING BORE	ID	5.2486 5.2500	5.2520
3	SLEEVE BEARING SEAT	OD	4.2500 4.2507	4.2480
4	DRIVE LINK BUSHING	ID	0.4886 0.5000	0.5015
4A	SLEEVE	ID	1.1288 1.1255	1.1288
<b>TORQUE</b>				
5	NUT	IN./LB	200 400	
6	NUT	IN./LB	200 400	
7	NUT	FT./LB	150 300	
8	NUT	FT./LB	150 300	

AV 008041

Figure 2-2. Limits Charts - Scissors and Sleeve Assembly.

*effect repair as described. Do not use grinding wheel.*

*Polish out corrosion damage with fine to medium grade abrasive cloth (item 2, table 1-2) or fine India stone, and final polish to a scratch-free finish with crocus cloth (item 3, table 1-2).*

*Cadmium plating removed by repair should be reapplied by brush cadmium plating (item 4, table 1-2). Repair areas on aluminum anodized surfaces with brush alodine (item 9, table 1-2).*

**n.** Score marks on the inside surface of holes and bushings may be polished out if the damage is 0.002 inch or less.

**2-28. Lubrication.**

2-29. Lubricate mating surfaces during reassembly with oil (item 5, table 1-2). Use compound (item 6, table 1-2) on mating threads of dissimilar metal. Repack bearings that do not have lubrication fittings, before reassembly, with grease (item 7, table 1-2).

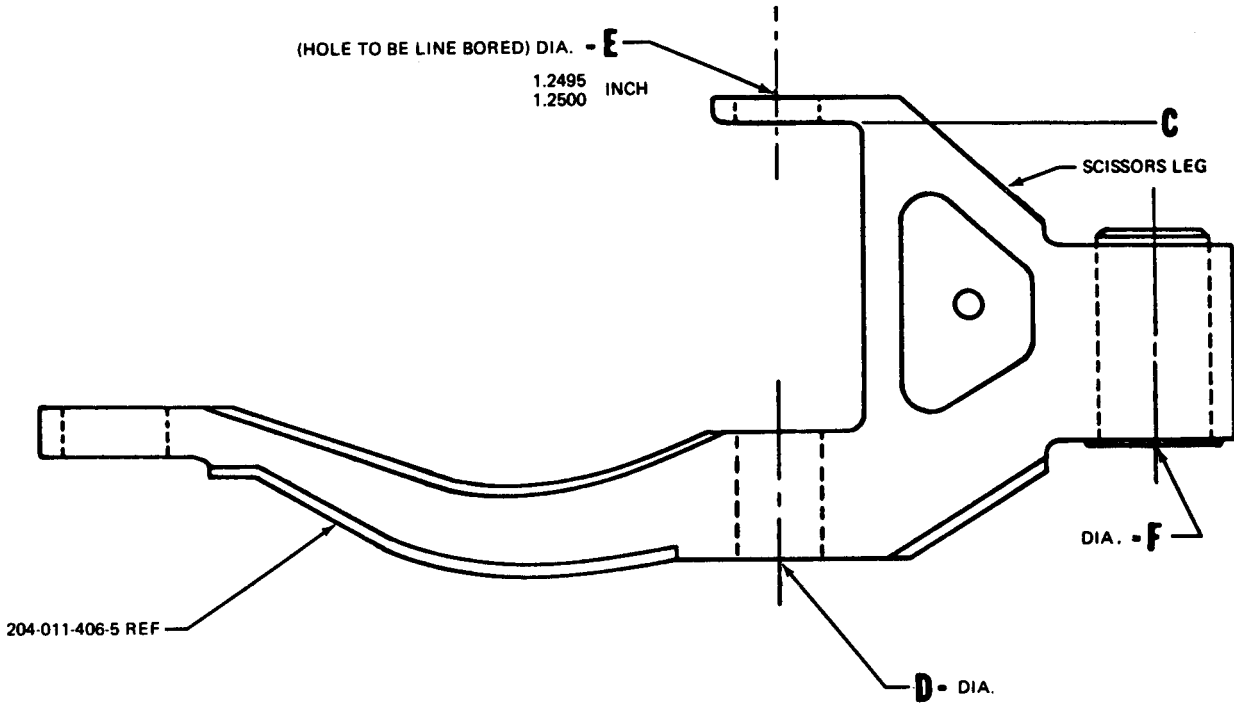

DIA. <b>E</b>	
SQUARE WITHIN .0005 / INCH	SURF <b>C</b>
CONCEN .003 T.I.R.	DIA <b>D</b>
PARALLEL WITHIN .001 / INCH	DIA <b>F</b>

TABLE 1

AV 009951

Figure 2-3. Scissors Assembly

**2-30. Modification Data.**

a. Modification of Scissors In order to modify assembly (204-011-406-5) to scissors assembly (204-011-406-9) the following changes shall be accomplished at overhaul after disassembly, inspection and cleaning of the scissors assembly.

(1) Line bore a hole (1.2496 to 1.2500inch in diameter) in leg of the scissors assembly part number 204-011-406-5. (See figure 2-3.)

*NOTE*

*Hole to be line bored must be square, concentric, and parallel in accordance with tolerances called out in table 1, figure 2-3.*

(2) Machine a chamfer (0.020 x 45°) at inboard and outboard circumference of hole line bored leg of scissors assembly part number, 204-011-406-5 in step (1).

(3) Clean hole to remove oil and shavings.

(4) Spray a heavy coat of primer (item 12, table 1-2) in bore of scissors assembly and on outer surface of sleeve part number, 204-011-4561. Allow at least 16 minutes for primer to dry.

(5) Coat outer surface of sleeve and bore of scissors with compound (item 8, table 1-2).

*NOTE*

*Apply compound (item 8, table 1-2) with a swab. Use pressure to work sealant onto sleeve OD. and bore scissors of leg..*

(6) Press deeve into bored leg of scissors assembly.

*NOTE*

*Support opposite side of leg during pressureing operation to prevent damage to scissors.*

(7) Clean excess sealant from sleeve and leg of scissors.

(8) Ensure sleeve is flush with inner surface of scissors assembly leg.

(9) Allow two hours for assembly to dry.

(10) Reidentify scissors assembly as part number, 204-011-406-9. Annotate appropriate records Use rubber stamp method of marking.

*NOTE*

*It is possible to obtain scissors assemblies part number, 204-011-406-5, with the bearing part number, AN 2011 CP8A, installed in the scissors leg. When assemblies are obtained in this condition, push out bearing, remove sealant, and proceed with modification.*

*NOTE*

*It is also possible to obtain scissors assemblies part number, 204-011-406-5, with a 4130 steel sleeve preeded in bored hde scissors leg. Beam-ng part number AN 2011CP8A, and this sleeve are sealed in the scissors leg and are identified by letter M stamped on the scissors and sleeve assembly. When scissors are obtained in this condition, push out sleeve and bearing, dean sealant from bored hole, and remove or canal out the letter M from scissors and sleeve assembly. Proceed with modification.*

**CAUTION**

***Extreme care shall be taken when removing the loctite from the bored hole because the hole is already bored to dimension specified.***

b. Modification of Scissors and Sleeve Assembly. Modification of scissors and sleeve assemblies (204-011-401-5 and -7) to the 204-011-401-11 configuration is accomplished by replacement of parts. See the "usable on" code in the key to figure 2-1.

(1) Conversion of scissors and sleeve assembly (204-01 1-401-5) to the 204-011401-11 configuration is accomplished by the addition of safety washers (15) and washers (16) and the replacement of hub (37), scissors (6), collective sleeve (45), plate (33), bolt (4), bolt (14), and spacer (17).

(2) Conversion of scissors and sleeve

assembly (204-011-401-7) to the 204-011-401-11 configuration is accomplished by the addition of safety washers (15) and washers (16), the replacement of plate (33), spacer (17), bolt (14), and bolt (4); and the reworking of scissors (204-011-406-5) to the 204-011-406-9 configuration (paragraph 2-30).

c. Preserve, package, pack and mark scissors and sleeve assembly (204011-401-11) in accordance with figure 4-1.

### 2-31. Reassembly.

### 2-32. Hub And Collective Sleeve.

2-33. Reassemble hub and collective sleeve as follows:

a. Use T101382 adapter to install new seal (44, figure 2-1) in nut (36). Place nut, with seal lip down, loosely on sleeve (45), below shoulder.

b. Assemble bearing set (42) and spacer set (43) as shown, with V-mark on bearing outer races aligned and pointing up. (See view A, figure 2-1). Use T101382 adapter to press two lower bearings of bearing set (42) on upper end of sleeve. Press spacer set (43) and upper bearing of bearing set (42) on upper end of sleeve.

c. Start left-hand threaded nut (41) on sleeve. Install T101302 wrench with pin engaged in holes of nut. Hold sleeve with T101424 bar inserted through lower end. Torque nut 150 to 200 foot-pounds. Align holes of nut and sleeve at one place and insert pin (40). Install lockwire through drilled head pin in space between nut and sleeve. (See view (D)). A sign-off inspection is required to insure the installation of pins and lockwire.

d. Press new seal (38), with lip pointing up, into top of hub (37) with T101382 adapter, flush with (or slightly below) lower edge of hub seal bore.

e. Place sleeve assembly on a press, with T101369 support halves under outer race of lower bearing. Place spacer ring (39) on upper bearing. Press hub assembly down over bearings. Remove assembly from press.

f. Install T101392 wrench on top of hub with two bolts. Invert assembly and secure wrench in a vise. Start lower nut (36) into hub and torque 150 to 200 foot-pounds using wrench T101493. Install lock plate (35), with tabs engaged in two slots of nut. If lock plate does not align, use new lock plate and drill two 0.198- to 0.204-inch holes to match existing tapped holes in hub. Secure to hub with two screws (34). Lockwire screw heads together. Turn assembly upright and remove tools. A sign-off inspection is required to insure the installation of lockplate and lockwire.

g. Install plate set (33, figure 2-1) and flange (32) on top of hub with six bolts (30) and aluminum alloy washers (31). Lock wire bolt heads in sets of three.

### 2-34. Scissors Assembly.

2-35. Reassemble scissors assembly as follows:

au. Coat exterior of liner (19) and scissors assembly bore with primer (item 12, table 1-2), allow to dry and coat with compound (item 15, table 1-2).

a. Install pivot bearing liner (19) in scissors. Press shim (21) into pivot bearing liner. Press bearing set (20) into liner with V-mark pointing inboard.

b. With the bearing set seated, measure the distance between inside of scissors leg and inner race of triplex bearing.

c. If measurement is not within tolerance (3.990--4.000 inches) remove bearing set (20) and peel or add sufficient shims to meet the dimensions.

d. Reinstall bearing set and again measure the distance between inside of scissors leg and inner race of bearing.

e. Repeat this procedure until the proper dimension is met.

### 2-36. Scissors And Sleeve Assembly.

2-37. Reassemble scissors and sleeve assembly as follows:

a. Position scissors assembly on hub (37) with spacer (18) installed between trailing edge of hub and triplex bearing (20, figure 2-1).

b. Install washer (16) between bearing (51) and safety washer (15) on bolt (14) as required to maintain a minimum clearance of 0.010 inch between washer (15) and scissors assembly.

c. Install bolt (14), spacer (17) and nut (13). Tighten nut (13) to a torque of 200-400 inch-pounds and secure with cotter pin (12). A sign-off inspection is required to insure the installation of cotter pin.

d. Ensure freedom of operation and end play on hub (37).

e. Install shim (11) between bearing set (20) and pivot bearing spacer (10) to obtain 0.003 inch to 0.009 inch extension of spacer outside pivot bearing liner.

f. Install cover plate (9). Secure with nuts (7) and washers (8).

g. Ensure a new seal (716223) (24) is installed in housing assembly (23). Assemble thrust washer (25) and housing assembly (23) over leading edge of bearing (29).

h. Position drive link (5) on scissors with straight edge of scissors in a leading position (see figure 2-1). Install bolt (4) with washer (3) under head of bolt (4). Install shim (22) between housing and link



as required to obtain 0.000 inch to 0.002 inch gap (see view C). This measurement should be taken between the shim (22) and housing assembly (23). Install washer (3) and nut (2). Tighten nut to a torque of 200-400 inch-pounds. Install cotter pin (1). A sign-off inspection is required to insure the installation of cotter pin.

*NOTE*

*There should be NO end play at inner race. A total end play of 0.038 inch to 0.082 inch is required between drive link and scissors. This end play should be equally divided on both sides.*

i. Install opposite scissors assembly and drive link in the same manner.

j. Ensure lubrication of all points provided with lubrication fittings. Lubricate with grease (item 7, table 2-1).

### **2-38. Painting Requirements.**

Identify lube fittings by painting a 1/8 inch wide band, 1/2 inch to 1 inch O.D. around fitting with Acrylic Lacquer per Fed Std 595, Color No. 17038 (Gloss Black). As an alternate method, the band may be made from pressure sensitive tape, 3M Scotchcal, No. 3655 (Black) or equivalent.

### **2-39. Final Reassembly. (Not Applicable)**



**Section III. FINAL TEST PROCEDURES**  
**(Not Applicable)**



Section IV. PRESERVATION, PACKAGING, PACKING AND MARKING REQUIREMENTS

4-1. Preservation, Packaging, Packing, And Marking Requirements

for scissors and sleeve assembly part numbers 204011-401-9 and 204011401-11 shall be in accordance with figure 4-1.

4-2. Preservation, packaging, packing, and marking

<b>PRESERVATION, PACKAGING, PACKING AND MARKING REQUIREMENTS</b>																	
NOMENCLATURE  Scissors and Sleeve Assembly			STOCK NUMBER 1615-863-1147														
			PART NUMBER 204-011-401-5														
NET WEIGHT 39 lbs		DIMENSIONS 19 x 19 x 10		GROSS WEIGHT CUBIC FEET													
<i>All specifications and standards applicable to the requirements herein shall be the issue in effect on date of invitation for bids.</i>																	
PACKAGING <input checked="" type="checkbox"/> LEVEL A <input type="checkbox"/> LEVEL C <input checked="" type="checkbox"/> PACKAGING SHALL BE IN ACCORDANCE WITH SPECIFICATION MIL-P-118. THE FOLLOWING DETAILED REQUIREMENTS SHALL APPLY:																	
<table border="1" style="width:100%; border-collapse: collapse;"> <thead> <tr> <th style="width:15%;">UNIT PKG QTY</th> <th style="width:15%;">METHOD</th> <th style="width:15%;">PRESERVATIVE</th> <th style="width:15%;">WRAP</th> <th style="width:15%;">DUNNAGE</th> <th style="width:15%;">CONTAINER</th> </tr> </thead> <tbody> <tr> <td style="text-align: center;">1</td> <td style="text-align: center;">IId</td> <td style="text-align: center;">P-11</td> <td style="text-align: center;">MIL-B-121 Gr A or Polyethylene</td> <td style="text-align: center;">MIL-C-7769 or MIL-P-26514</td> <td style="text-align: center;">See Packing</td> </tr> </tbody> </table>						UNIT PKG QTY	METHOD	PRESERVATIVE	WRAP	DUNNAGE	CONTAINER	1	IId	P-11	MIL-B-121 Gr A or Polyethylene	MIL-C-7769 or MIL-P-26514	See Packing
UNIT PKG QTY	METHOD	PRESERVATIVE	WRAP	DUNNAGE	CONTAINER												
1	IId	P-11	MIL-B-121 Gr A or Polyethylene	MIL-C-7769 or MIL-P-26514	See Packing												
<input type="checkbox"/> PRESERVATION AND PACKAGING SHALL BE SUCH AS TO PREVENT DETERIORATION OR DAMAGE DURING HANDLING AND SHIPMENT TO THE FIRST DESTINATION.																	
<input type="checkbox"/> OTHER.																	
PACKING <input checked="" type="checkbox"/> LEVEL A <input type="checkbox"/> LEVEL C <input checked="" type="checkbox"/> ITEMS SHALL BE PACKED IN CONTAINERS CONFORMING TO SPECIFICATION NO. FSN 8115-020-8858 <input checked="" type="checkbox"/> PLYWOOD USED SHALL BE STANDARD GRADE WITH EXTERIOR GLUE OF U.S. PRODUCT STANDARD PSI-86. THIS PLYWOOD SHALL HAVE THE GRADE STAMP OF AN APPROVED TESTING AGENCY. FURTHER, PLYWOOD SHALL BE SURFACE TREATED IN ACCORDANCE WITH SPECIFICATION TT-W-372. WOOD CLEATED PLYWOOD CONTAINERS SHALL BE CONSTRUCTED WITH THE TOP INVERTED SO AS TO PROVIDE A FLUSH TOP SURFACE FOR WATER RUNOFF.																	
<input type="checkbox"/> ITEM SHALL BE PACKED IN A MANNER TO INSURE CARRIER ACCEPTANCE AND SAFE DELIVERY AT DESTINATION. CONTAINERS SHALL BE IN ACCORDANCE WITH UNIFORM FREIGHT CLASSIFICATION RULES OR REGULATIONS OF OTHER CARRIERS APPLICABLE TO THE MODE OF TRANSPORTATION.																	
<input type="checkbox"/> OTHER.																	
MARKING <input checked="" type="checkbox"/> a. IN ADDITION TO ANY SPECIAL MARKING REQUIRED BY THE CONTRACT OR ORDER, SHIPMENT SHALL BE MARKED IN ACCORDANCE WITH STANDARD MIL-STD-129D, WITH CHANGE NOTICE 1 THRU 9. "MARKING FOR SHIPMENT AND STORAGE," DATED 28 DECEMBER 1964. THE SERIAL NUMBER AND THE CONTROL NUMBER OF DA FORM 2410 SHALL BE MARKED ON THE UNIT CONTAINER.																	
<input checked="" type="checkbox"/> b. ADDITIONAL MARKING REQUIREMENTS. EACH INTERIOR PACKAGE SHALL BE MARKED ON AT LEAST TWO (2) SIDES WITH A SILHOUETTE OF THE AIRCRAFT. (WHERE THE SIZE OF THE UNIT CONTAINER IS TOO SMALL TO PERMIT THE APPLICATION OF TWO (2) LABELS, A SINGLE LABEL SHALL BE APPLIED. IF THE PACKAGE IS TOO SMALL FOR ONE (1), NONE WILL BE REQUIRED.) WHEN THE UNIT CONTAINER IS THE SHIPPING CONTAINER AND THE ITEM IS PACKED "LEVEL A", EACH CONTAINER SHALL BE MARKED ON TWO (2) SIDES, TOP AND ONE (1) END WITH A SILHOUETTE OF THE AIRCRAFT. THE SIZE OF THE SILHOUETTE MAY VARY, BUT WILL BE LARGE ENOUGH TO FACILITATE EASY VISUAL IDENTIFICATION WITHOUT OBSCURING OTHER MARKINGS. THE CONTRACTING OFFICER WILL SUPPLY LABELS ON REQUEST. THE NOMENCLATURE OF THE MAJOR COMPONENTS SHALL BE EXTENDED TO INDICATE THE END ITEM APPLICATION AND THE POSITION OF THE PART: e.g., GEAR BOX, MAIN FOR (APPL CABLE AIRCRAFT); WING ASSEMBLY, RIGHT, FOR (APPLICABLE AIRCRAFT).																	
<input type="checkbox"/> c. MATERIEL CONDITION MARKINGS SHALL BE APPLIED IN ACCORDANCE WITH PARAGRAPH 5.8.17 OF MIL-STD-129. A MATERIEL CONDITION TAG OF THE APPLICABLE TYPE WILL BE SECURELY ATTACHED DIRECTLY TO ALL UNINSTALLED OR STORED AERONAUTICAL OR AIR DELIVERY ITEMS. WHEN SUCH ITEMS ARE PLACED OR STORED IN CARTONS, PACKAGES, CRATES OR METAL SHIPPING CONTAINERS, A DUPLICATE MATERIEL CONDITION TAG OR LABEL WILL BE SECURELY ATTACHED TO THE EXTERIOR OF THE PACKAGE OR CONTAINER IN SUCH A MANNER THAT WILL AFFORD MAXIMUM PROTECTION FROM HANDLING AND WEATHER. TAGS WILL BE COMPLETED EITHER BY TYPEWRITING OR PRINTED BLACK LEAD PENCIL ENTRIES. ITEMS OF A COMMON OR NONTECHNICAL NATURE (i.e., COMMON HARDWARE, BULK MATERIALS, ETC.) THE SERVICEABILITY OF WHICH IS OBVIOUS, AND THE IDENTITY AND INSPECTION REQUIREMENTS ADEQUATELY INDICATED BY COMMERCIAL TAGS, LABELS OR MARKINGS, MAY BE RECEIVED, STORED, ISSUED OR SHIPPED WITHOUT MATERIEL CONDITION TAGS.																	
APPROVED BY  H. H. Hill		ORGANIZATION  AMSAV-R-MC		DATE  7 October 1973													

AV 008042

Figure 4-1. Preservation, Packaging, Packing, and Marking Requirements.

|

-

-

-

|

-

|

-

## Section V. DIFFERENCE DATA SHEETS

### 5-1. Difference Data Sheets

Overhaul instructions for the model included in this section are the same as the procedures for the specified model covered in the preceding section of this technical manual, except for the differences noted herein.

5-2. The instructions contained in the preceding

sections, for scissors and sleeve assembly, 204-100401-11 apply to the 204-100-401-9 except for the differences noted in this difference data sheet.

5-3. Plate 204-010-479-11 is used on scissors and sleeve assembly 204-011401-9 whereas plate 204-010479-17 is used on scissors and sleeve assembly 204-011-401-11.





## APPENDIX A REFERENCES

TM 38-750	The Army Maintenance Management System
MIL-I-6868	Magnetic Particle Inspection
MIL-I-6866	Fluorescent Penetrant Inspection
MIL-B-15319	Brush Platers



## **APPENDIX B REPAIR PARTS AND SPECIAL TOOLS LIST**

**(Not Applicable)**

★ U. S. GOVERNMENT PRINTING OFFICE: 1975--665689/63



ALPHABETICAL INDEX

	Paragraph
<b>A</b>	
<b>B</b>	
<b>C</b>	
Cleaning .....	2-11
Cleaning-Drive links, scissors, hub, and collective sleeve assemblies .....	2-12
Consumable materials .....	1-15 T1-2
<b>D</b>	
Descriptionand leading particulars .....	1-11
Difference datasheets .....	5-1
Disassembly .....	2-1
Driveling .....	2-5
Drivelink-inspection .....	2-15
Drivelink-repair andreplacement .....	2-22
<b>E</b>	
Equipmentrecords .....	1-9
<b>F</b>	
Final reassembly .....	2-38
<b>G</b>	
General information .....	1-1
<b>H</b>	
Hub and collective sleeve .....	2-9
Hub and collective sleeve-inspection .....	2-19
Hub and collective sleeve-reassembly .....	2-31 2-32
Hub and collective sleeve-repair and replacement .....	2-26
<b>I</b>	
Inspectionaftercleaning .....	2-14
<b>J</b>	
<b>K</b>	
<b>L</b>	
Lubrication .....	2-28
<b>M</b>	
Modification data .....	2-30
<b>N</b>	
Nondestructiveinspectiontestdata .....	T2-1
<b>O</b>	
<b>P</b>	
Painting requirements .....	2-37
Preservation, packaging, packing, and marking requirements .....	4-1
Preservation, packaging, packing, and markingrequirements .....	F4-1
Purposeoftheequipment .....	1-7
<b>Q</b>	
Quality control personnel .....	1-5

R

Reporting of errors ..... 1-2

S

Scissors ..... 2-7  
Scissors assembly-inspection ..... 2-17  
Scissors assembly-reassembly ..... 2-33  
Scissors assembly-repair and replacement ..... 2-24  
Scissors and sleeve assembly ..... F1-1  
..... 2-3  
Scissors and sleeve assembly-exploded view ..... F2-1  
Scissors and sleeve assembly-reassembly ..... 2-25  
Special tools and test equipment ..... T1-1

T

Test equipment, special tools, and materials ..... 1-13

U

V

W

X

Y

Z

(1) SMR CODE	(2) FEDERAL STOCK NUMBER	(3) DESCRIPTION				USABLE ON CODE	(4) UNIT OF ISSUE	(5) QTY INC IN UNIT	(6) 30-DAY MAINT ALW			(7) 1-YR ALWPER 100 EQUIP CNTGCTY	(8) DEPOT MAINT ALWPER 100 EQUIP	(9) ILLUSTRATION	
		(a) 1-20	(b) 21-50	(c) 51-100	(a) FIG NO				(b) ITEM NO						
	1615-454-8828	204-011-401-11	(97499)	SCISSORS AND SLEEVE ASSEMBLY.....	A	EA							1-1		
	1615-957-7316	204-011-401-9	(97499)	SCISSORS AND SLEEVE ASSEMBLY.....	B	EA							1-1		
	1615-856-3918	204-011-401-7	(97499)	SCISSORS AND SLEEVE ASSEMBLY.....	C	EA							1-1		
	1615-863-1147	204-011-401-5	(97499)	SCISSORS AND SLEEVE ASSEMBLY.....	D	EA							1-1		
Section II. REPAIR PARTS															
SCISSORS AND SLEEVE ASSEMBLY															
P--O--	5315-234-1864	MS24665-302	(96906)	PIN, COTTER.....		EA	4	*	*	*			2-1	1	
P--O--	5310-263-2862	MS21045C3	(96906)	NUT, SELF-LOCKING, HEXAGON.....		EA	4	*	*	*			2-1	2	
P--O--	5310-167-0751	AN960PD816	(88044)	WASHER, FLAT.....		EA	V	*	*	*			2-1	3	
P--O--	5306-771-6031	NAS464P8-69	(80205)	BOLT, SHEAR.....		EA	2	*	*	*			2-1	4	
P--O--	1615-830-9750	204-011-407-1	(97499)	LINK ASSEMBLY, SWASHPLATE AND.....		EA	2	*	1	2	24		2-1	5	
COLLECTIVE SLEEVE															
P--F--	1615-938-9784	204-011-406-13	(97499)	SCISSORS ASSEMBLY.....		EA	2	1	2	5	55		2-1	6	
P--O--	5310-263-2862	MS21045C3	(96906)	NUT, SELF-LOCKING, HEXAGON.....		EA	2	*	*	*			2-1	7	
P--O--	5310-183-4406	AN960PD10	(88044)	WASHER, FLAT.....		EA	4	*	*	*			2-1	8	
P--O--	1615-847-8365	204-010-456-3	(97499)	COVER, ACCESS.....		EA	2	*	1	1	17		2-1	9	
P--F--	5340-838-1598	204-010-455-3	(97499)	SPACER, SLEEVE.....		EA	2	*	*	*	10		2-1	10	
P--F--	5340-782-8511	120-045-35-29	(97499)	SHIM.....		EA	2	2	4	9	106		2-1	11	
P--F--	5315-234-1864	MS24665-302	(96906)	PIN, COTTER.....		EA	4	*	*	*			2-1	12	
P--F--	5310-176-8112	AN320-8	(88044)	NUT, SLOTTED, HEXAGON.....		EA	4	*	*	*			2-1	13	
P--F--	5306-767-5050	NAS464P8-90	(80205)	BOLT, SHEAR.....		EA	2	*	*	*			2-1	14	
MF--O--		204-011-459-1	(97499)	WASHER, FLAT.....	AB		2						2-1	15	
P--O--	5310-167-0839	AN960-816L	(88044)	WASHER, FLAT.....	AB	EA	4	*	*	*			2-1	16	
P--F--	5340-841-9950	NAS43HT8-21	(80205)	SPACER, SLEEVE.....	BCD	EA	2	*	*	*			2-1	17	
P--F--	5340-813-8832	NAS43HT8-18	(80205)	SPACER, SLEEVE.....	AB	EA	2	*	*	*			2-1	17	
P--F--	5310-838-7061	204-011-448-1	(97499)	WASHER, FLAT.....		EA	2	*	*	*			2-1	18	
P--F--	1615-830-9726	204-010-454-3	(97499)	LINER, BEARING HOUSING.....		EA	2	*	1	2	24		2-1	19	
P--F--	3110-731-7977	204-011-412-1	(97499)	BEARING, BALL, STACK ROTOR BLADE.....		SE	2	3	7	13	158		2-1	20	
P--F--	5340-782-8511	120-045-35-29	(97499)	SHIM.....		EA	V	REF	REF	REF	REF		2-1	21	
P--O--	5340-842-0669	120-045-27-17	(97499)	SHIM.....		EA	V	*	1	2			2-1	22	
P--F--	1615-830-9751	204-011-421-1	(97499)	HOUSING ASSEMBLY, DRIVE LINK.....		EA	2	*	1	1	17		2-1	23	
P--F--	5330-839-5862	71X6223	(73680)	SEAL, PLAIN, ENCASED.....		EA	1	*	*	*			2-1	24	
P--F--	3120-839-5431	204-011-420-1	(97499)	WASHER, THRUST.....		EA	2	1	2	5	58		2-1	25	
P--F--	3110-840-2716	204-010-441-3	(97499)	RING, BEARING, INNER.....		EA	2	1	2	4	46		2-1	26	
P--F--	3110-840-8610	204-011-418-1	(97499)	BEARING, ROLLER, NEEDLE.....		EA	2	1	2	5	58		2-1	27	
P--F--	1615-830-9752	204-011-422-1	(97499)	SPACER, SLEEVE.....		EA	2	1	2	3	41		2-1	28	
P--F--	3110-840-8611	204-011-419-1	(97499)	BEARING, ROLLER, NEEDLE.....		EA	2	1	3	5	65		2-1	29	
P--F--	5306-182-2016	AN4H5A	(88044)	BOLT, MACHINE.....		EA	6	*	*	*			2-1	30	
P--F--	5310-187-2354	AN960PD416	(88044)	WASHER, FLAT.....		EA	6	*	*	*			2-1	31	
P--H--	1615-649-8229	204-010-445-1	(97499)	FLANGE, SCISSORS AND SLEEVE.....		EA	1	*	*	*	2		2-1	32	
P--H--	1615-454-8780	204-010-479-17	(97499)	PLATE SET, COLLECTIVE PITCH DRIVE...	A	EA	1	*	*	1	7		2-1	33	

(1) SMR CODE	(2) FEDERAL STOCK NUMBER	(3) DESCRIPTION REFERENCE NUMBER & MFR CODE		USABLE ON CODE	(4) UNIT OF MEAS	(5) QTY INC IN UNIT	(6) 30-DAY GS MAINT ALW			(7) 1-YR ALWPER 100 EQUIP CNTGCV	(8) DEPOT MAINT ALWPER 100 EQUIP	(9) ILLUSTRATION	
							(a) 1-20	(b) 21-50	(c) 51-100			(a) FIG NO	(b) ITEM NO
P--H--	1615-860-9508	204-011-454-1	(97499)		EA	1	*	*	1	10		2-1	35
AH-F--		204-010-437-5	(97499)			1						2-1	36
P--H--	1615-580-2008	204-010-428-1	(97499)		EA	1	*	*	1	10		2-1	
P--H--	5310-788-0048	204-010-437-7	(97499)		EA	1	*	*	*			2-1	
P--H--	1615-970-1259	204-011-405-9	(97499)		EA	1	*	*	*			2-1	37
P--H--	5305-253-5606	MS21318-7	(96906)		EA	2	*	*	*			2-1	38
P--F--	5340-847-1132	204-011-411-1	(97499)		EA	1	*	*	*			2-1	39
P--F--	5315-860-9527	204-011-453-1	(97499)		EA	1	*	*	1	10		2-1	40
P--F--	1615-649-8226	204-010-420-1	(97499)		EA	1	*	*	*	2		2-1	41
P--F--	5340-847-1132	204-011-411-1	(97499)		EA	1	*	*	*			2-1	42
P--H--	1615-735-6554	204-011-410-1	(97499)		EA	1	*	*	*	2		2-1	43
P--H--	1615-580-2008	204-010-428-1	(97499)		EA	1	*	*	REF	REF		2-1	44
P--H--	1615-873-2309	204-011-408-3	(97499)		EA	1	*	*	*			2-1	45
P--H--	3120-847-3401	85B10-31-35-48	(97499)		EA	4	1	2	44	53		2-1	46
P--H--	3120-847-2708	85B7-19-27-18	(97499)		EA	4	*	*	*	5		2-1	47
P--O--	4730-277-4780	NAS516-1	(80205)		EA	2	2	4	8	96		2-1	48
P--F--	3110-702-1453	MS28913-5A	(96906)		EA	2	1	1	3	31		2-1	49
P--H--	3120-759-3797	204-011-456-1	(97499)		EA	2	*	1	2	22		2-1	50
P--H--	3110-142-4472	MS20201KP8A	(96906)		EA	2	*	*	*			2-1	51
P--H--	1615-898-0051	204-011-413-1	(97499)		EA	2	*	*	*	5		2-1	52
MAINTENANCE SUPPLIES													
P--F--	5310-167-0768	MS63040-6	(96906)		EA	V	*	*	*			MSUP	
P--O--	5350-221-0872				EA	V	*	*	*			MSUP	
P--O--	5350-246-0330				SH	V	*	*	*			MSUP	
P--F--	6810-281-2785				GL	V	*	*	*			MSUP	
P--F--	6850-285-8011				GL	V	*	*	*			MSUP	
P--F--	7920-244-7431				EA	V	*	*	*			MSUP	
P--F--	8010-899-0931				QT	V	*	*	*			MSUP	
P--O--	8030-081-2336				CC	V	*	*	*			MSUP	
P--F--	8030-231-2353				LB	V	*	*	*			MSUP	
P--F--	8030-613-3131				OZ	V	*	*	*			MSUP	
P--F--	8030-980-3976				OZ	V	*	*	*			MSUP	
P--O--	9150-263-3490				QT	V	*	*	*			MSUP	
P--O--	9150-616-9020				LB	V	*	*	*			MSUP	

TM 55-1615-226-40



(1) SMR CODE	(2) FEDERAL STOCK NUMBER	REFERENCE NUMBER & MFR CODE	(3) DESCRIPTION	USABLE ON CODE	(4) UNIT OF MEAS	(5) QTY INC IN UNIT	(6)			(7) 1-YR ALWPER 100 EQUIP CNTGCT	(8) DEPOT MAINT ALWPER 100 EQUIP	(9) ILLUSTRATION	
							30-DAY MAINT ALW	GS	51-100			(a) FIG NO	(b) ITEM NO
							(a) 1-20	(b) 21-50	(c) 51-100				
			Section III. SPECIAL TOOLS, TEST AND SUPPORT EQUIPMENT										
P--H--	4920-713-5553	T101392	(97499) WRENCH, SCISSORS AND SLEEVE.....		EA	1	1	1	1				TOOL
P--H--	4920-713-5555	T101382	(97499) RAM ADAPTER, SCISSORS AND SLEEVE.... ASSEMBLY		EA	2	1	1	1				TOOL
P--H--	4920-786-1756	T101369	(97499) SUPPORT, SCISSORS AND SLEEVE.....		EA	1	*	*	*				TOOL
P--H--	4920-876-0102	T101424	(97499) BAR, BEARING REMOVAL.....		EA	1	1	1	1				TOOL
P--H--	5120-837-9483	T101493	(97499) WRENCH, SPANNER.....		EA	1	2	2	2				TOOL

STOCK NUMBER	FIGURE NUMBER	ITEM NUMBER	STOCK NUMBER	FIGURE NUMBER	ITEM NUMBER
1615-454-8780	2-1	33	5306-182-2016	2-1	30
1615-454-8828	1-1		5306-767-5050	2-1	14
1615-580-2008	2-1		5306-771-6031	2-1	4
1615-580-2008	2-1	44	5310-167-0751	2-1	3
1615-649-8226	2-1	41	5310-167-0768	MSUP	
1615-649-8229	2-1	32	5310-167-0839	2-1	16
1615-735-6554	2-1	43	5310-176-8112	2-1	13
1615-830-9726	2-1	19	5310-183-4406	2-1	8
1615-830-9750	2-1	5	5310-187-2354	2-1	31
1615-830-9751	2-1	23	5310-263-2862	2-1	2
1615-830-9752	2-1	28	5310-263-2862	2-1	7
1615-847-8365	2-1	9	5310-788-0048	2-1	
1615-856-3918	1-1		5310-838-7061	2-1	18
1615-860-9508	2-1	35	5315-234-1864	2-1	1
1615-863-1147	1-1		5315-234-1864	2-1	12
1615-873-2309	2-1	45	5315-860-9527	2-1	40
1615-898-0051	2-1	52	5330-839-5862	2-1	24
1615-938-9784	2-1	6	5340-782-8511	2-1	11
1615-957-7316	1-1		5340-782-8511	2-1	21
1615-970-1259	2-1	37	5340-813-8832	2-1	17
3110-142-4472	2-1	51	5340-838-1598	2-1	10
3110-702-1453	2-1	49	5340-841-9950	2-1	17
3110-731-7977	2-1	20	5340-842-0669	2-1	22
3110-840-2716	2-1	26	5340-847-1132	2-1	39
3110-840-8610	2-1	27	5340-847-1132	2-1	42
3110-840-8611	2-1	29	5350-221-0872	MSUP	
3120-759-3797	2-1	50	5350-246-0330	MSUP	
3120-839-5431	2-1	25	681 0-281-2785	MSUP	
3120-847-2708	2-1	47	6850-285-8011	MSUP	
3120-847-3401	2-1	46	7920-244-7431	MSUP	
4730-277-4780	2-1	48	8010-899-0931	MSUP	
4920-713-5553	TOOL		8030-081-2336	MSUP	
4920-713-5555	TOOL		8030-231-2353	MSUP	
4920-786-1756	TOOL		8030-613-3131	MSUP	
4920-876-0102	TOOL		8030-980-3976	MSUP	
5120-837-9483	TOOL		9150-263-3490	MSUP	
5305-253-5606	2-1	38	9150-616-9020	MSUP	

REFERENCE NUMBER	MFG CODE	FIG NUMBER	ITEM NUMBER	REFERENCE NUMBER	MFG CODE	FIG NUMBER	ITEM NUMBER
AN320-8	88044	2-1	13	204-010 -441-3	97499	2-1	26
AN4H5A	88044	2-1	30	204-010 -445-1	97499	2-1	32
AN960-816L	88044	2-1	16	204-010 -454-3	97499	2-1	19
AN960PD10	88044	2-1	8	204-010 -455-3	97499	2-1	10
AN960PD416	88044	2-1	31	204-010 -456-3	97499	2-1	9
AN960PD816	88044	2-1	3	204-010-479-17	97499	2-1	33
MS20201KP8A	96906	2-1	51	204-011-401-11	97499	1-1	
MS21045C3	96906	2-1	2	204-011 -401-5	97499	1-1	
MS21045C3	96906	2-1	7	204-011 -401-7	97499	1-1	
MS21318-7	96906	2-1	38	204-011 -401-9	97499	1-1	
MS24665-302	96906	2-1	1	204-011 -405-9	97499	2-1	37
MS24665-302	96906	2-1	12	204-011-406-13	97499	2-1	6
MS28913-5A	96906	2-1	49	204-011 -407-1	97499	2-1	5
MS63040-6	96906	MSUP		204-011 -408-3	97499	2-1	45
NAS43HT8-18	80205	2-1	17	204-011 -410-1	97499	2-1	43
NAS43HT8-21	80205	2-1	17	204-011 -411-1	97499	2-1	39
NAS464P8-69	80205	2-1	4	204-011 -411-1	97499	2-1	42
NAS464P8-90	80205	2-1	14	204-011 -412-1	97499	2-1	20
NAS516-1	80205	2-1	48	204-011 -413-1	97499	2-1	52
T101369	97499	TOOL		204-011 -418-1	97499	2-1	27
T101382	97499	TOOL		204-011-419-1	97499	2-1	29
T101392	97499	TOOL		204-011-420-1	97499	2-1	25
T101424	97499	TOOL		204-011 -421-1	97499	2-1	23
T101493	97499	TOOL		204-011 -422-1	97499	2-1	28
120-045-27-17	97499	2-1	22	204-011 -448-1	97499	2-1	18
120-045-35-29	97499	2-1	11	204-011 -453-1	97499	2-1	40
120-045-35-29	97499	2-1	21	204-011 -454-1	97499	2-1	35
204-010-420-1	97499	2-1	41	204-011-456-1	97499	2-1	50
204-010-428-1	97499	2-1		204-011 -459-1	97499	2-1	15
204-010-428-1	97499	2-1	44	71X6223	73680	2-1	24
204-010-437-5	97499	2-1	36	85 B10-31-35-48	97499	2-1	46
204-010-437-7	97499	2-1		85 B7-19-27-18	97499	2-1	47



TM 55-1615-226-40 is published for the use of all concerned.

By Order of the Secretary of the Army:

Official:

VERNE L. BOWERS  
*Major General, United States Army*  
*The Adjutant General*

FRED C. WEYAND  
*General, United States Army*  
*Chief of Staff*

DISTRIBUTION:

To be distributed in accordance with DA Form 12-31, Direct and General Support Maintenance requirements for UH-1B, UH-1C, UH-1D and 1H aircraft.





